

Installation Instructions



Weight of heaviest part 7kg (Metallophone)

1. Attach the steel mount to the rear of the instrument with the M8 x20 screws and 2 part security caps. (1.1) (See Assembly Guide)

2. Position instrument in desired location, according to correct Key stage height, this may require 2 persons.

3. Mark hole locations (X4) using the pre drilled holes in square plate. Use Template Supplied.

4. Drill hole locations (X4) according to your chosen fixings (frame fixings, wall bolts or chemical anchors) depending of the structure of the wall. (Not Supplied)

5. Fix through Plate with suitable fixings (not supplied) in correct orientation and height for intended Key stage. Cover Fixings with 2 Part Caps supplied

6. Attach the 1 pair of beater to the saddle strap on the leg. (1.3)

Install Instrument with 1m free space (from widest point) around it.

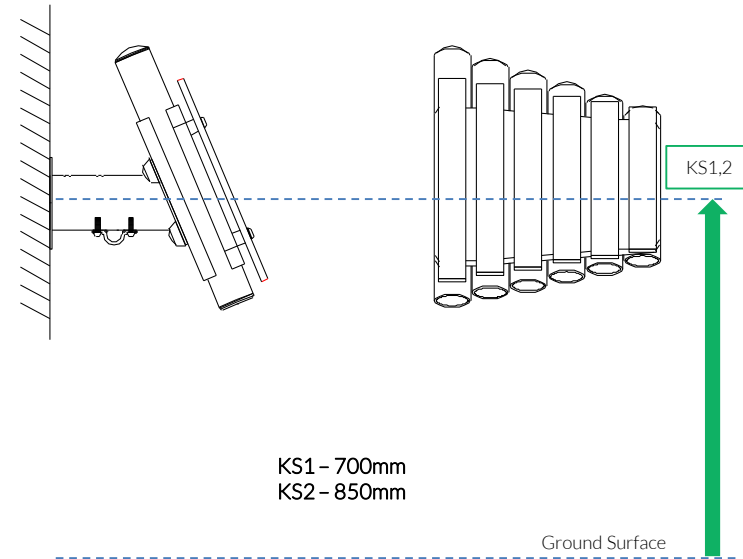
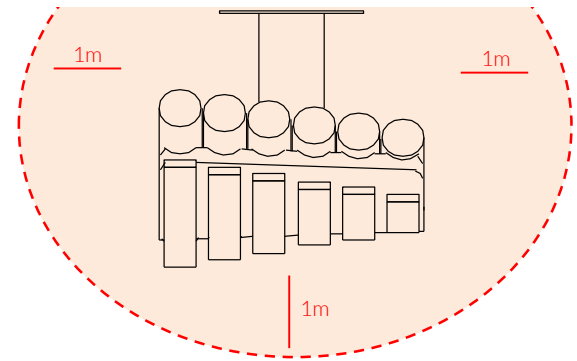

KS1 - 700mm
KS2 - 850mm

Ground Surface

KS1,2

Wall Fixed Rainbow Trio Metallophone Page 1 of 2



Instrument Components:

-  x4
- M8x20 Security Screw**
-  x2
- M6x20 Security Screw**
-  x4
- 2 Part Cover Cap**
-  x1
- M6 Saddle Strap**

Metric Conversion:
700mm/ 28"
850mm/ 33"
1m/ 39"



Pair Small Red Beaters X1

Wall Fix Components:



x4
2 Part Cover Cap

Wall Anchors not supplied

Spares available from
percussionplay.com or from your
local distributor

7 Kg

Tools:

 x1
  x1

Wall Fixed
Rainbow Trio
Metallophone
Page 2 of 2





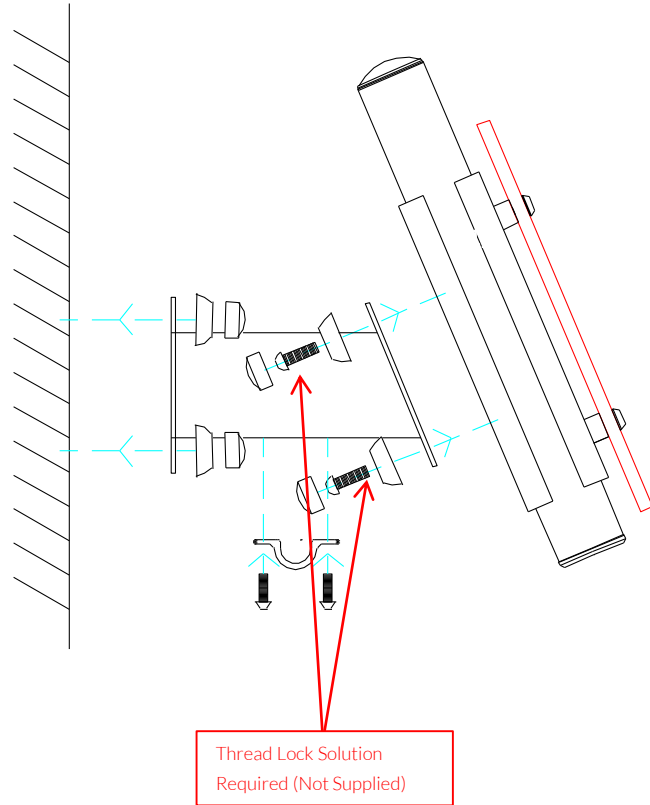

Instrument Components:

-  x4
M8x20 Security Screw
-  x2
M6x20 Security Screw
-  x4
2 Part Cover Cap
-  x1
M6 Saddle Strap



COMPONENTS LIST:

-  2 Part Cover Cap X8
-  M8 Nyloc nut X4
-  Saddle Strap X1
-  M6x20 Pin torx X2
-  M8x20 Pin torx X4

Thread Lock Solution
Required (Not Supplied)



Pair Small Red Beaters X1

Wall fixings are not supplied, installer will select suitable method of fixing. Suggested Fixing M8-M10 Rawl Bolt



Spares available from percussionplay.com or from your local distributor

7 Kg